

# AUTOMATIC CONTROL FOR A DIESEL GENERATOR

P-127

## Project Report

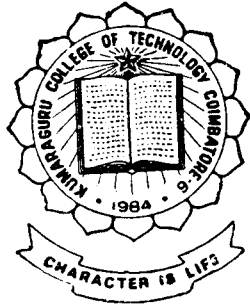

SUBMITTED IN PARTIAL FULFILMENT OF THE  
REQUIREMENTS FOR THE AWARD OF THE DEGREE OF  
**BACHELOR OF ENGINEERING IN  
ELECTRICAL AND ELECTRONICS  
ENGINEERING**  
OF BHARATHIAR UNIVERSITY

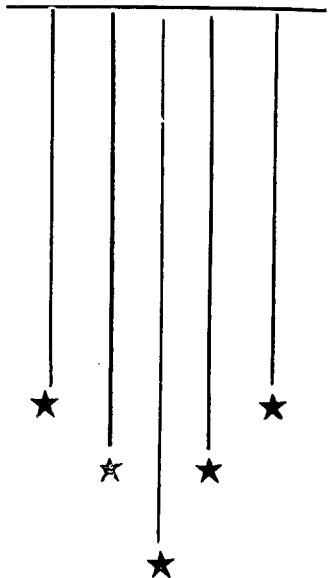

1992-93

Submitted by

R. Venkatesh babu  
D. Mahesh kumar  
C. Loganathan

Guided by

Miss. B. Anamahestrari, B.E., MISTE.,

Department of Electrical and Electronics Engineering

**KUMARAGURU COLLEGE OF TECHNOLOGY**

COIMBATORE-641 006

Dr. K. A. PALANISWAMY, B.E., M.Sc. (Engg), Ph.D.,  
M.T.E.C, Engg (I.), F.I.E.,

## ACKNOWLEDGEMENT

We are greatly thankful to our guide **Miss.B.UMA MAHESWARI B.E.,MISTE.,** for the excellent guidance and encouragement to complete this project.

We are immensely thankful to **Dr.K.A.PALANISWAMY, B.E., M.sc. (Engg.).., Ph.D., MISTE., C.Eng(I),FIE.,** Professor and Head of the Department of Electrical and Electronics Engineering for his benevolence and blessings in our attempt .

We are thankful to **Major .T.S.RAMAMURTHY,** Principal for his encouragement throughout the project.

We are grateful to **Prof.N.A.GNANAM** of G.C.T, Coimbatore for helping us in all sorts.

We also thank all the teaching and non teaching staff members of the Electrical and Electronics Engineering Department for their help and encouragement.

## SYNOPSIS

Automatic control for a diesel generator is very essential at the places where power failure causes a great concern. This project suggests a method to start and stop the diesel generator automatically, whenever the EB power is interrupted. If the EB power fails, within about five seconds the diesel generator starts to run and provides the electric supply, and change over is automatically done. When the EB supply comes, then the supply to the load will be changed over from diesel generator to the EB supply automatically. The diesel generator will be stopped within the next ten seconds. All the above operations are performed automatically. We have provisions also made for semi automatic remote control for the diesel generator.

DEDICATED

TO

OUR PARENTS

## CONTENTS

CHAPTER NUMBER	TITLE	PAGE NUMBER
	CERTIFICATE	
	ACKNOWLEDGEMENT	
	SYNOPSIS	
I	INTRODUCTION	1
II	SEMI AUTOMATIC REMOTE CONTROL	
2.1	NECESSARY IMPROVEMENTS IN SEMIAUTOMATIC REMOTE CONTROL	3
2.2	START OPERATION	4
2.3	STOP OPERATION	5
2.4	NORMAL/D.G. CHANGE OVER SYSTEM	6
2.5	ADVANTAGE	7
2.6	DIS ADVANTAGE	7
III	AUTOMATIC CONTROL.	
3.1	SEQUENCE OF START OPERATION	9
3.2	SEQUENCE OF STOP OPERATION	10
3.3	ALTERATION DONE IN DUAL HEAD LAMP RELAY	12
3.4	START OPERATION	14
3.5	STOP OPERATION	14
3.6	ADVANTAGE	17

IV	COMPONENTS OF AUTOMATIC SYSTEM.	
4.1	SENSING ELEMENT	18
4.2	START TIMER CIRCUIT	18
4.3	STOP TIMER CIRCUIT	19
4.4	TRANSISTOR AS A SWITCH	20
4.5	SOLENOID	22
4.6	RELAY	24
4.7	CONTACTOR	26
4.8	DIESEL ENGINE	28
4.9	THREE PHASE GENERATOR	35
4.10	DC SERIES MOTOR	38
4.11	MAIN COMPONENTS LIST	40
V	<b>CONCLUSION</b>	41
	REFERENCES	43

## CHAPTER 1

### INTRODUCTION

The diesel generator of any industry or factory is normally installed at a place far off from the control room. In case of power supply failure, it is a laborious and time consuming process to go and switch on and then to switch off. If the firm is powered by diesel generator then the delay in switching on the generator results in prolonged service interruptions.

At most of the stations, it is observed that only remote starting facility is provided by putting a parallel push button. Since the stop operation is not remote, there is an inherent delay in switching off the generator due to obvious reasons, resulting in wastage of fuel.

In order to eliminate the delay in switching on and off and also to reduce the wastage of fuel and time, it is necessary to have the provision of both start and stop operation of generator from remote.

In almost all the diesel generators, a starting push button is provided. A very heavy current flows through this push button in order to operate the starting solenoid. More over the generator does not

start with a momentary push of a button. So the button has to be pressed for atleast two to three seconds.

Therefore ,it is not desirable to provide a remote starting pushbutton in parallel to it eventhough it is found that at many places a parallel pushbutton is brought on the control pannel. This requires a heavy-duty push button, a heavy - duty battery cable and above all the battery gets discharged soon.

Stop operation in a diesel generator is not economical. In order to stop the generator , the fuel supply cut off lever has to be kept pulled till the generator comes to a dead halt . If the lever is released before the generator comes to a dead halt, it picks up speed again and restarts. Thus the stop operation is rather complicated.



## CHAPTER 2

### SEMIAUTOMATIC REMOTE CONTROL

#### 2.1 NECESSARY IMPROVEMENTS IN SEMIAUTOMATIC REMOTE CONTROL.

1. Diesel generator should start with a momentary push of a button.

2. It should also stop with a momentary push of another button .

3. It should have an automatic cut off for the starting solenoid . Otherwise there is a possibility of the starting solenoid keeping the starting motor engaged with the generator for longer time and ultimately both the motor and solenoid may get destroyed .

4. It should also have an automatic cutout for the stop solenoid . This is essential. Otherwise, the solenoid will burn if the supply is not disconnected due to some fault in the circuit.

5. Proper inter locking between the start and the stop push buttons should be there. This means that while the generator is off, stop push button should be made inoperative. And also, when the generator is on, start pushbutton should be made inoperative.

6. There should be a remote switch on the generator panel in order to ensure the safety of the personnel working on the generator.

## 2.2 START OPERATION :

Once start pushbutton S1 is momentarily pressed, capacitor C2 charges to approximately +7 volts, and transistor T1 is instantly driven into saturation, energising relay RL2 in its collector circuit. Capacitor C2 keeps providing base current to T1 through 10 K resistor and hence T1 remains in conduction, keeping the relay energised even after the pushbutton is released.

But after 3 seconds, C2 does not provide sufficient base voltage to keep transistor T1 into saturation and hence it is pulled out of conduction and the relay in its collector circuit gets de-energised. The normally-open contact of the relay RL2 extends +12 v to the dual head lamp relay (RL4 and RL5) coils simultaneously. The start solenoid gets supply through the normally-open contacts of RL4 and RL5 connected in series as shown. Thus the diesel engine starts.

After 3 seconds, relay RL2 gets de-energised

and the supply to the solenoid is disconnected . once the generator picks up speed and the output voltage becomes normal, relay RL1 gets energised. This relay also interrupts 12v supply to the dual relays through one of its pairs of contacts. Coils of dual relays RL4 and RL5 have been energised and their contacts connected in series to extend supply to the start solenoid, in order to ensure positive tripping in case any one of the relays get stuckup. Relay RL1 with one of its pairs of contacts gives an indication of diesel generator 'on' condition by flashing an LED on the control panel.

### **2.3 STOP OPERATION:**

For pulling the cutoff lever, a 12 v solenoid is used. This solenoid is mounted on the generator in such a manner that it pulls the cut off lever completely, when it get's energised.

when the diesel generator is not running and the stop pushbutton S2 is pressed, transistor T2 does not get base drive, since the normally open contact of relay RL1 is included in series with stop pushbutton. When the diesel generator is on, relay RL1 is energised. Now when the stop pushbutton is pressed momentarily, Transistor T2 instantly conducts into saturation and relay RL3 in its collector circuit gets energised.

Capacitor C3 keeps T2 on, and hence the Relay RL3 on for about 10 seconds. With the normally - open contact of RL3, supply is extended to dual head lamp Relay RL5 to its 'b'coil. Thus with its RL5b contact, stop solenoid is energised and it pulls the cutoff lever. Since Relay RL3 remains energised for 10 seconds, and so does the dual relay coil RL5L, the solenoid keeps the cutoff lever pulled for 10 seconds, and the generator stops.

#### 2.4 NORMAL DIESEL GENERATOR CHANGE OVER SYSTEM:-

Here the change over from normal to DG and from DG to normal is done automatically.

As shown in fig. 2.1 the coil circuit of the normal supply contactor is normally closed and hence normal supply is always through. Whenever EB supply fails, then the supply to the coil circuit of the normal contactor is cutoff and the contactor opens. Then the DG is started automatically (or semiautomatically pressing start pushbutton). Changeover to diesel generator supply takes place automatically once the generator attains full speed. This is achieved by including the normally closed contact of relay RL2 in the DG contactor coil circuit.

Also when the generator is switched off the DG supply is automatically changed over to normal supply. This is so because the normally closed contact of relay RL3 is included in the DG contactor coil circuit.

The circuit diagram for semiautomatic remote control is shown in fig.2.1.

## **2.5 ADVANTAGE OF SEMIAUTOMATIC REMOTE CONTROL :**

1. By this semi automatic remote control, it is very easy to start or stop the DG from remote areas.

2. It is not necessary to go to the generator room to start or stop the diesel generator.

3. From the above point it is understood that the time taken to operate the generator by this method is comparatively less.

## **2.6 DISADVANTAGE OF SEMIAUTOMATIC REMOTE CONTROL :**

The only disadvantage in this system is that we have to keep watching on the EB supply every time in order to switch off the generator. If EB supply is not watched properly then the fuel will be wasted.

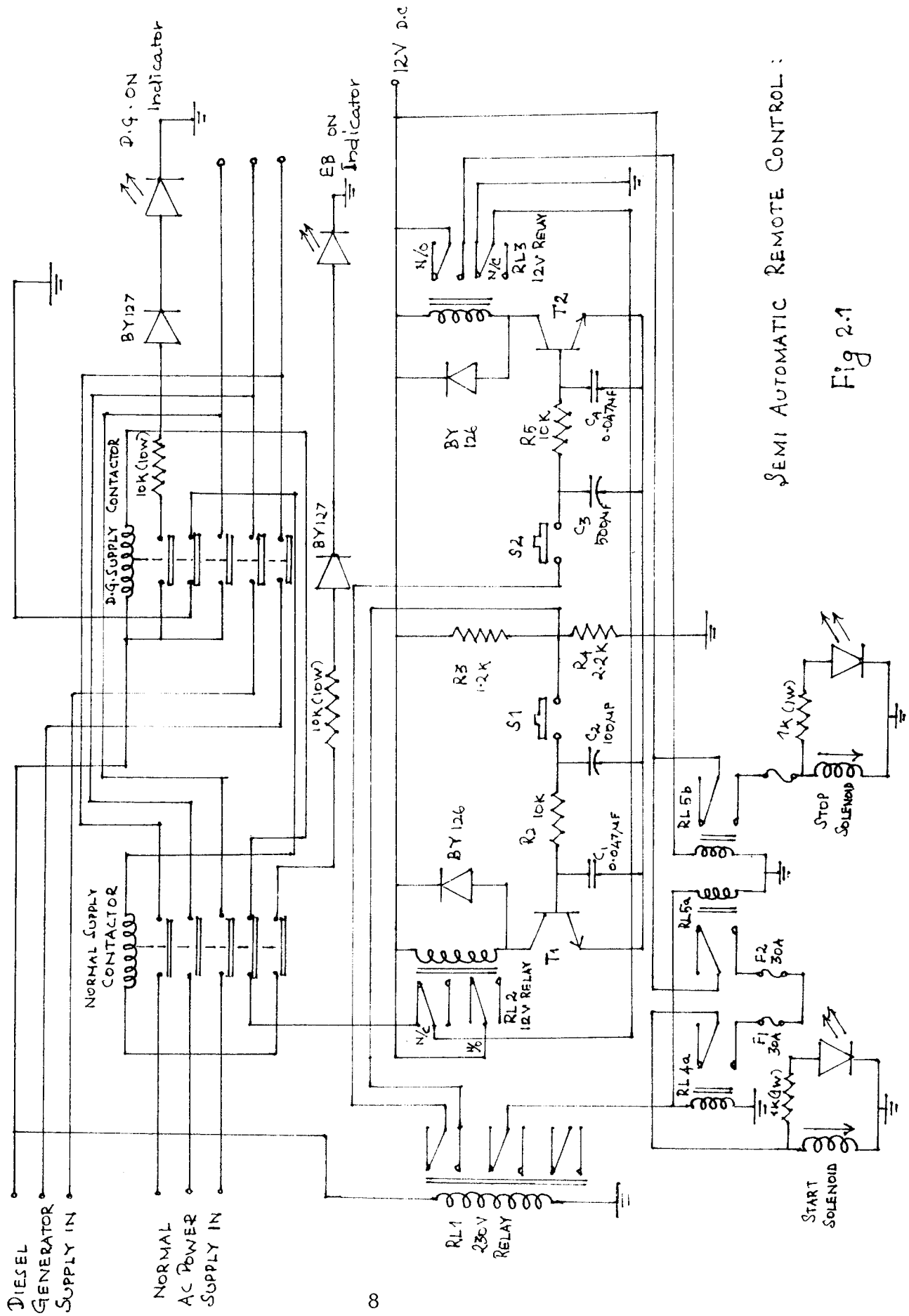

SEMI AUTOMATIC REMOTE CONTROL :

Fig 2.1

## CHAPTER 3

### AUTOMATIC CONTROL

To eliminate the above disadvantage in semiautomatic remote control we are going for automatic control. In automatic control the push buttons are eliminated and the control is done automatically using sensing element. Here momentary contacts are achieved, which operates the dual head lamp relay.

#### 3.1 SEQUENCE OF START OPERATION IN AUTOMATIC CONTROL

1. Sense the EB supply.
2. If EB supply fails, operate the start button manually.
3. The start timer circuit operates for 3 seconds.
4. Simultaneously the auxiliary 12v relay operates.
5. This 12 Volt auxiliary relay inturn operates the main dual head lamp relay.
6. 12 volt dc is supplied from battery to the start solenoid and operates it through the dual head lamp relay until the start timer circuit operates.
7. Thus the solenoid starts the starting motor and runs the diesel generator. DC series motor is used as the starting motor.

8. The changeover from the normal supply to the DG supply takes place automatically.

The block diagram for start operation is shown in fig.3.1.

### 3.2 SEQUENCE OF STOP OPERATION IN AUTOMATIC CONTROL

1. Sense for EB supply.

2. If EB supply comes, operate the stop button manually.

3. Change over to the normal EB supply from DG supply.

4. The stop timer circuit operates for about 15 seconds.

5. Simultaneously the auxiliary 12 V relay operates.

6. This auxiliary relay in turn operates the main stop dual head lamp relay.

7. 12 V DC is supplied from battery to the stop solenoid to operate it, through the dual head lamp relay until the stop timer circuit operates.

8. Thus the stop solenoid pulls the fuel cut Off lever of Diesel engine and stops the generator.

The block diagram for stop operation is shown in fig.3.2.



BLOCK DIAGRAM OF START OPERATION:

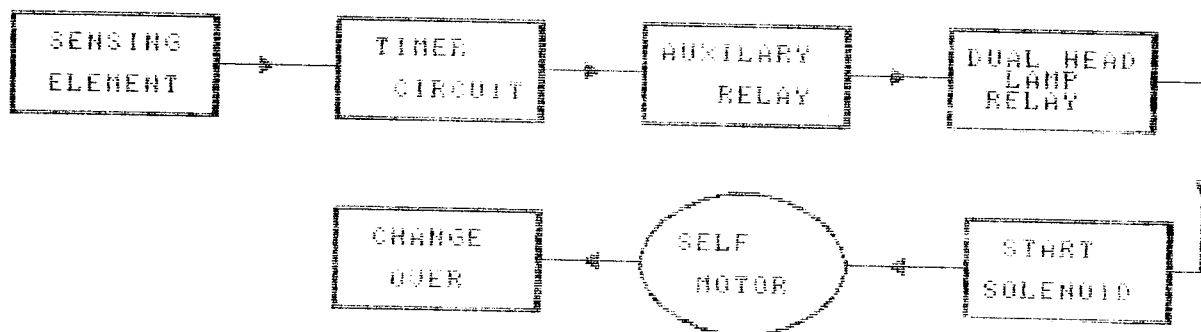

Fig 3.1

BLOCK DIAGRAM OF STOP OPERATION :

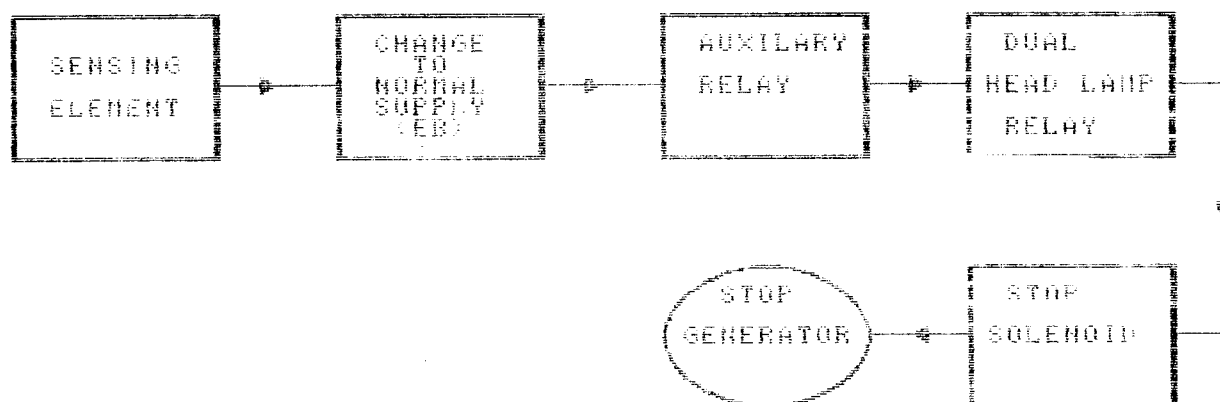

Fig 3.2



P-127

### 3.3 ALTERATION DONE IN DUAL HEAD LAMP RELAY FOR AUTOMATIC CONTROL

Dual head lamp relay is mostly used in automobiles. It has two separate coils. Whenever each coil is energised, that coil will magnetise the electromagnetic material placed inside the cylindrical coil and pulls the corresponding iron lever towards the coil. Here we need momentary contact to replace the push buttons. To achieve this we soldered a flexible steel strip with the moving arms of the relay. The vibration of the steel strip is used to get the momentary contact. There are two other fixed arms fitted so as to make momentary touch with the moving arm. One of the fixed arm is fitted in such away that it will make contact with the corresponding moving arm, when this arm is pulled by the electro magnet (A) and the other will make momentary contact with it's corresponding moving arm (B), when its electromagnet is demagnetised.

The diagram representing the dual head lamp is shown in fig.3.3

# DUAL HEAD LAMP RELAY

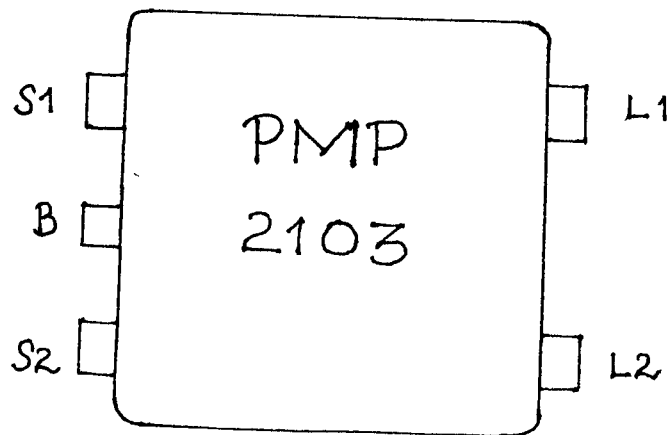
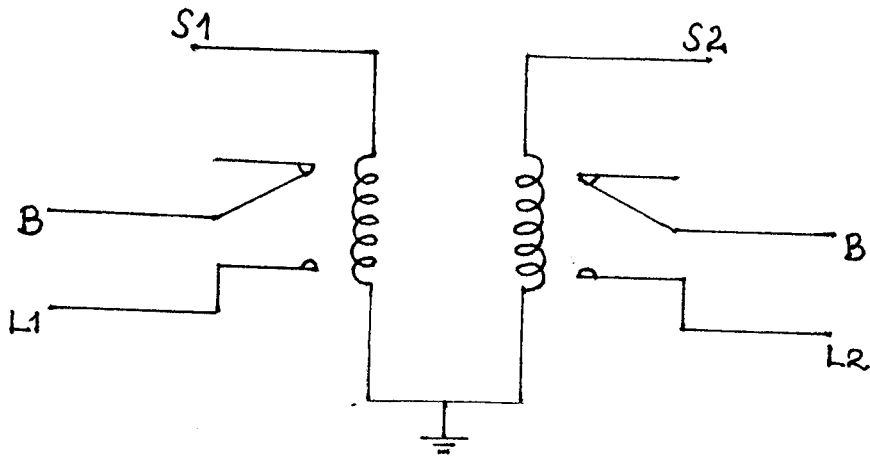

S1, S2 - RELAY COILS

B - COMMON BATTERY SUPPLY

L1, L2 - OUTPUT

Fig 3.3

### **3.4 START OPERATION IN AUTOMATIC CONTROL:**

The 230 volt EB supply is reduced to 12volt dc by using a step down transformer .This 12 volt is given to both the coils of the dual head lamp relay. When power failure occurs the moving arms of the relay will be released suddenly ,and the very first overshoot of the vibration of coil B will make momentary contact with the fixed contact and it charges the start capacitor of 100 micro farad.Thus the start switch is eliminated in automatic control .

### **3.5 STOP OPERATION IN AUTOMATIC CONTROL :**

Similarly when the EB supply comes it energises both coils of dual head lamp relay through the transformer ,fullwave rectifier arrangement. Now the very first overshoot of the vibrating arm (A) makes momentary contact with the corresponding fixed arm and thus energises the stop capacitor of 500 micro farad .Thus the stop push button is eliminated .In automatic control we have no problem in starting and stopping of the diesel generator . No time is wasted for starting and stopping and fuel wastage is avoided by this automatic control . There is a double pole single through switch is provided to operate the diesel generator in semi automatic or automatic mode .

There are four different coloured LEDs are provided to know wheter the EB supply has come or the diesel generator is operating . There are two other leds provided to know whether the start or stop solenoid is operating .

The circuit diagram for automatic control is shown in fig.3.4.



### 3.6 ADVANTAGES OF AUTOMATIC CONTROL

1. It is not necessary to watch the E.B supply after a break in order to stop the generator.

2. Since it is operating automatically there is no need for manual attention.

3. It reduces the power cut period for the firm.

4. We can avoid wastage of fuel.

5. By this method we can reduce the production loss due to power failure to a great extent.

## CHAPTER 4

### COMPONENTS OF AUTOMATIC SYSTEM

#### 4.1 SENSING ELEMENT:

A 230V/12V transformer acts as a sensing element. This 12 volt ac is converted to 12 v dc by using a fullwave bridge rectifier. This 12 volt dc supply is given to the dual head lamp relay for automatic switching. The start and stop push buttons are made inactive in automatic mode. They are active only in semi automatic mode. The push buttons are used in semi automatic remote controls, for getting momentary contact.

#### TIMER CIRCUIT:

Two RC timer circuits are used for energising start and stop solenoid.

#### 4.2 WORKING OF TIMER CIRCUIT DURING START OPERATION:

It is necessary to provide supply to the start solenoid for about 3 seconds. A transistor is used as a switch in this case. The transistor is made on by driving it into the saturation region from cutoff region by providing a base voltage of about 8 V through the R-C timer circuit. Initially



when the start switch is momentarily closed the capacitor C2 of 100 micro farads charges to 7 volts. The capacitor charges through the voltage divider network which consists of resistors R3 and R4. After 3 seconds the voltage across emitter to base of the transistor 1 goes below the cutoff voltage, and drives the transistor to cutoff region. During this 3 seconds the start solenoid will be energised through the dual head lamps relay. The capacitor C1 of very low value is used to reduce the noises.

#### **4.3 WORKING OF TIMER CIRCUIT DURING STOP OPERATION:**

When the stop push button is momentarily closed similar operation takes place as in the case of start operation. But it is necessary to provide supply to the stop solenoid, until the diesel generator comes to a dead halt. So it is necessary to give supply to the solenoid for about 15 seconds.

This is achieved by increasing the value of the capacitor C4. When stop push button is pressed transistor T2 is made on, which provides supply to the stop solenoid for about 15 seconds.

#### 4.4 TRANSISTOR AS A SWITCH :

When a transistor is used as a switch it is usually required to be brought alternatively in the saturation and in the cut off regions .When it is in saturation region it will be on so that the voltage drop across it is as near to zero as possible, and when it is in cut off region, it should carry almost no current so that it may be considered to be an open switch. It is found that the transistor doesn't respond instantaneously but takes a certain definite, though quite small, time in making a transition from one state to another. Consider the transistor switching circuit in which it is driven by an input pulse waveform which makes a transition from voltage level  $V_1$  to  $V_2$  at time  $t = 0$ , and after a time interval of  $T$  it again makes a transition from  $V_2$  to  $V_1$ . At  $V_1$  the transistor is at cutoff and at  $V_2$  it is in saturation.

Fig.4.1 shows the response of the collector current  $I_c$  to the input waveform  $V_i$  together with its time relationship to that waveform. It may be seen that the collector current  $I_c$  does not immediately respond to the transition in the input wave. Instead it rises to 10 % of its maximum value (saturation)  $I_{cs} = V_{cc}/R$ . This duration  $T_d$  is called delay time. Again, the current takes certain rise

# TRANSISTOR AS A SWITCH

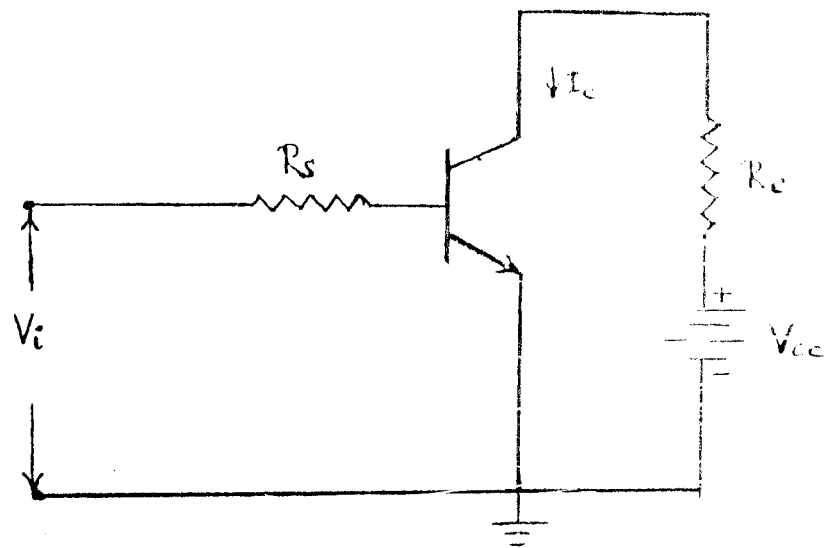
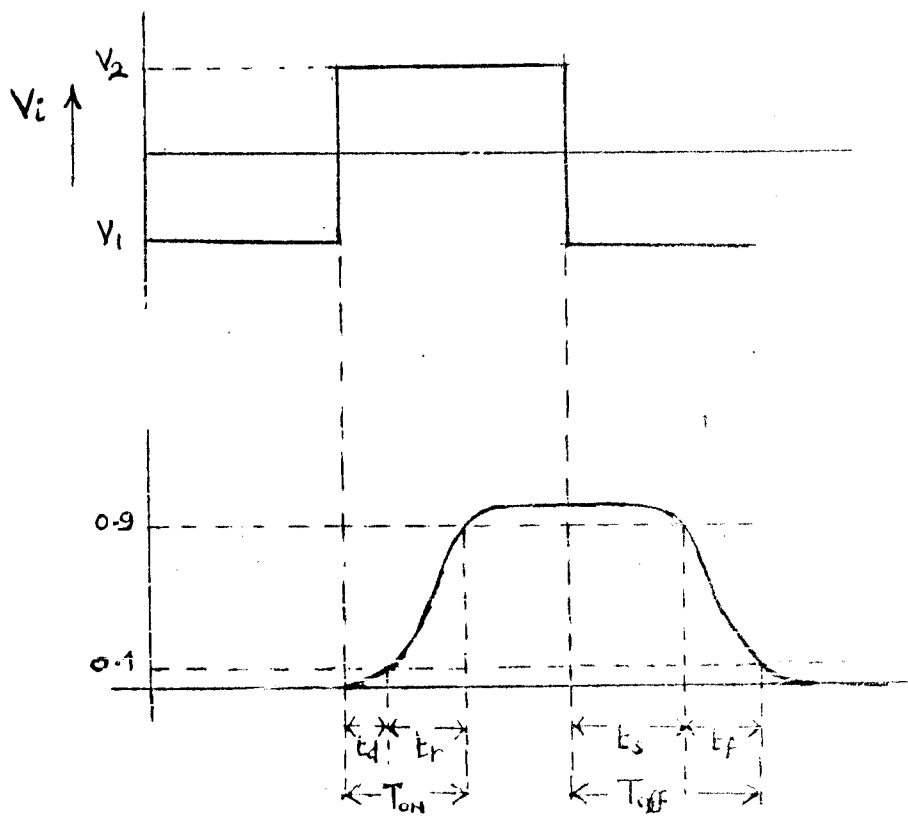

FIG 4-1



time  $T_r$  to rise from 10 to 90 % of  $I_{cs}$ . The total turn on time  $T_{on}$  is the sum of delay time and the rise time,  $T_{on}=T_d+T_r$ . When the input waveform makes another transition to return to its initial state at  $t=T$ , the output current again fails to respond instantaneously. The time interval taken by the current to 90% of the  $I_{cs}$  is called the storage time  $T_s$  and the time interval further taken by the current to fall from 90 to 10% of  $I_{cs}$  is called the fall time  $T_f$ . The turn off time is the sum of the storage time and the fall time,  $T_{off}=T_s+T_f$ . All these time intervals ( $T_d, T_r, T_s$  and  $T_f$ ) may have values ranging from 5 nano seconds to a few hundred nano seconds.

#### **4.5 SOLENOID:**

Push or Pull actuation can be provided by solenoids. But here it is used to pull the fuel cutoff lever of Diesel engine. It has a 12 Volt Coil, and an electromagnetic armature (plunger). This dc Solenoid is fabricated with a nonmagnetic tube separating the armature and coil winding.

Whenever the 12V supply is given to the coil of the solenoid then it becomes a hollow magnet and attracts the plunger towards the center of the coil. This 12V supply is given from the battery. It draws a

# SOLENOID SWITCH

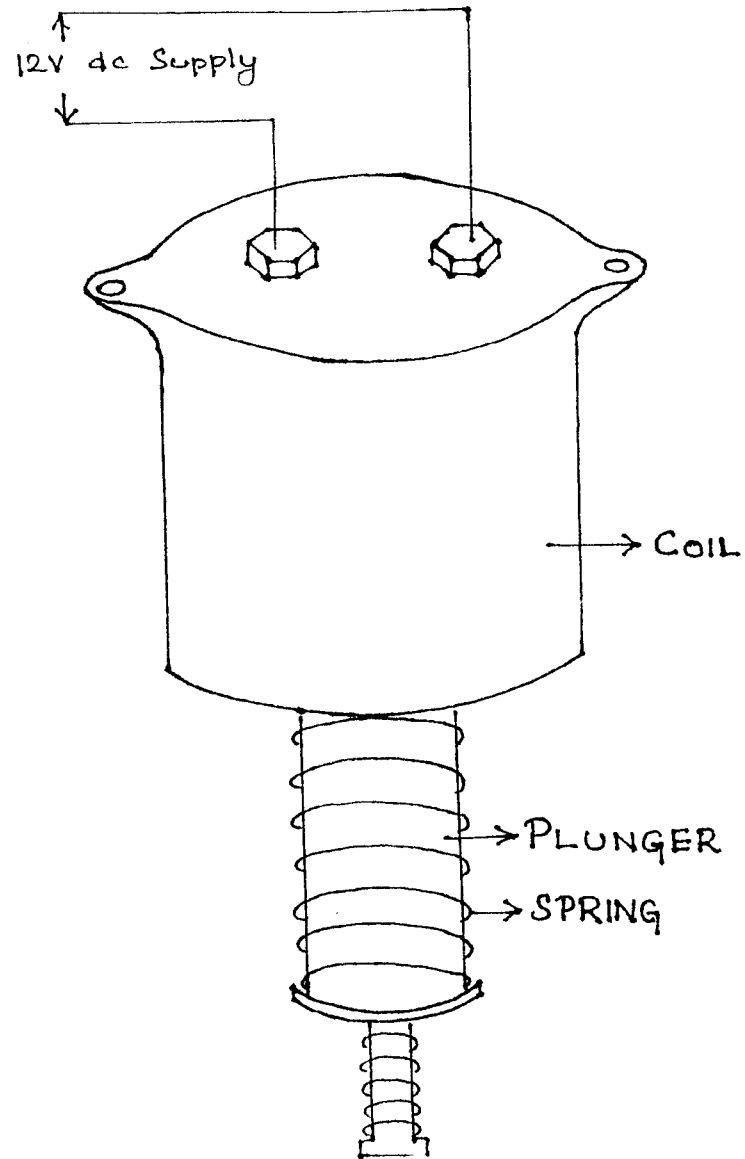

Fig 4.2

current of about 30A. If the 12V supply to the coil is cut off then the coil demagnetises and the plunger is released due to the opposing force provided by the spring arrangement. The pulling capacity of the solenoid can be increased by increasing the number of coil turns. The diagram of the solenoid switch is shown in fig.4.2

#### 4.6 RELAYS:

It works under the principle of electromagnetic attraction. Here we are using 12V relays. The 12V coil is wound on a bobbin and an electromagnet is placed inside the bobbin. Whenever the coil is energised by 12V dc supply the electromagnet attracts the jockey point, which is being a ferrous material. Each contact consists of one moving arm and two fixed arms. The contact can be normally opened (or) normally closed. The moving arm will be in contact with any one of the fixed arm all the time. If the coil is energised then moving arm will make contact with the another fixed arm.

In the above figure Coil AB is the magnetising Coil. Contact C1 is normally opened. Contact C2 is normally closed. Referring to figure 2, If the supply is given to the coil of the electromagnet It attracts the moving arm and connects

# RELAY:

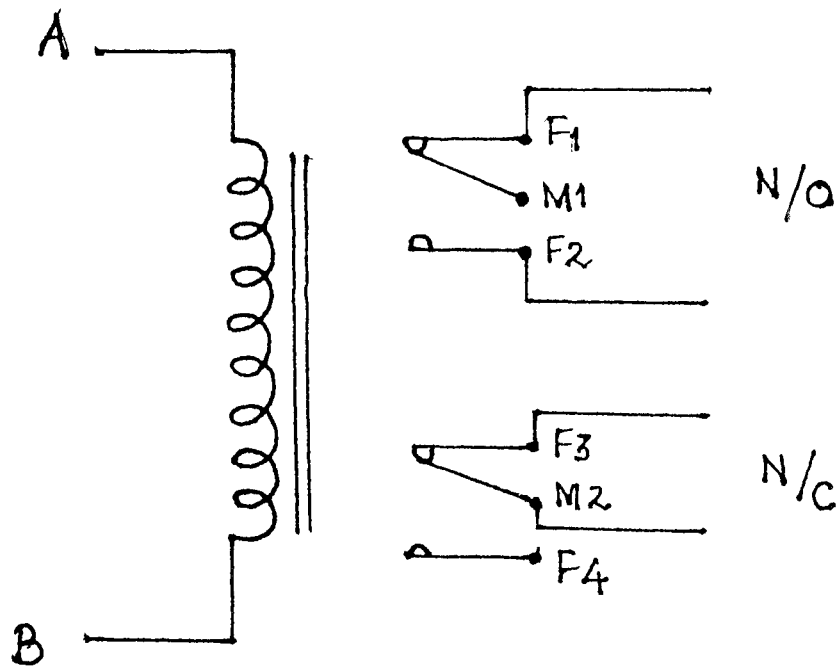

AB - RELAY COIL.

F1, F2, F3, F4 - FIXED ARMS.

M1, M2 - MOVING ARMS.

FIG 4.3

the moving arm with another fixed point and the previous fixed arm is opened.

The diagram 4.3 represents the 12 V relay.

#### **CONSTRUCTION:**

In this type of relays there are two electromagnetic coils which activates two separate contacts. Each unit contains a 12V Coil wound on a electromagnet. It has one moving arm and a fixed arm. Normally the contact will be open. When the coil is energised the moving arm is pulled down and makes contact with the fixed arm and closes the contact. These relays are designed so as to carry heavy currents upto 30A. Between the fixed and moving arm there is a fuse of 30A is provided for safety purposes.

Here B is the common supply to the moving arm. S is the supply lead to the 12V Coil and L is the output from the fixed arm. Each of the 12V coil can be individually operated.

#### **4.7 CONTACTOR:**

Here we are using an electromagnetic contactor. The opening and closing of main contactor is achieved by means of an electromagnet. Contactors are used here for the purposes of changeover. Each contactors



# CONTACTOR:

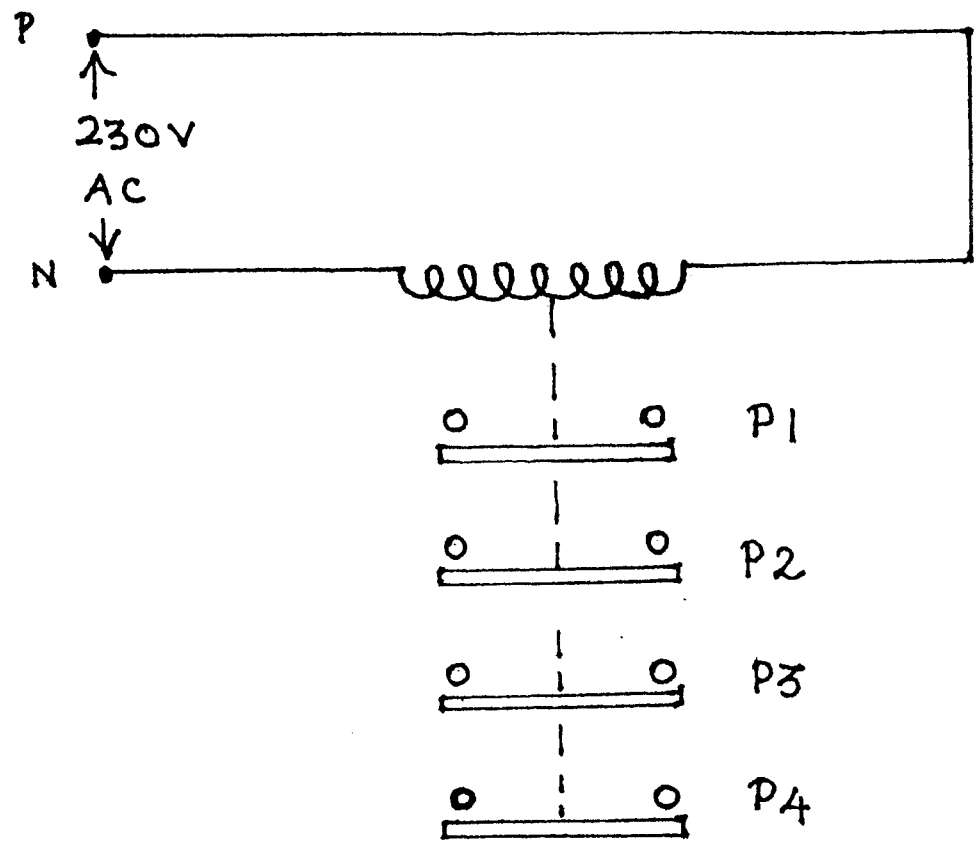

P<sub>1</sub>, P<sub>2</sub>, P<sub>3</sub>, P<sub>4</sub> - POLES .

FIG 4.4

contains a 230 Volt Coil which is used to magnetise an electromagnet. There are four poles present in one contactor. Each of the pole can be either normally opened or normally closed. These four poles are simultaneously activated by the 230 Volt Coil. It is possible to add upto four add-on N/O poles to the basic four pole contactor. The contactor rating is designed according to the connected loads. The fig.4.4 represents the contactor.

#### **DIESEL GENERATOR SET :**

This contains a diesel engine and a three phase alternator. The diesel engine acts as a prime mover for the generator.

#### **4.8 DIESEL ENGINE:**

A diesel engine is a prime mover which obtains its energy from a liquid fuel generally known as diesel oil and converts this energy into mechanical work. An alternator or a D.C. generator mechanically coupled to it converts the mechanical energy developed into electrical energy. It is compression-ignition type power source in which the heat for igniting the fuel charge is obtained from the compression of air in the engine cylinder before the fuel is introduced into it. It will also be observed that the main

difference between the diesel engine and steam turbine is that in the first case the chemical energy of combustion is released inside the cylinder while in the second case the energy developed during combustion of fuel is first transformed into steam and this in turn develops mechanical power in the turbine.

The diesel engines are most popular with small generating stations and with consumers who would like to have their own power supply for emergency reasons. They are also needed in medium sized power installations to either to supply the peak loads for small duration or for seasonal loads. At time of breakdown or for restarting boilers etc. It may also supply power to auxiliaries.

#### **CONSTRUCTION:-**

An understanding of the operation or purpose of the various parts is necessary for complete understanding of the whole engine. The main working parts of a compression ignition, four-stroke cycle engine are shown in fig.4.5.

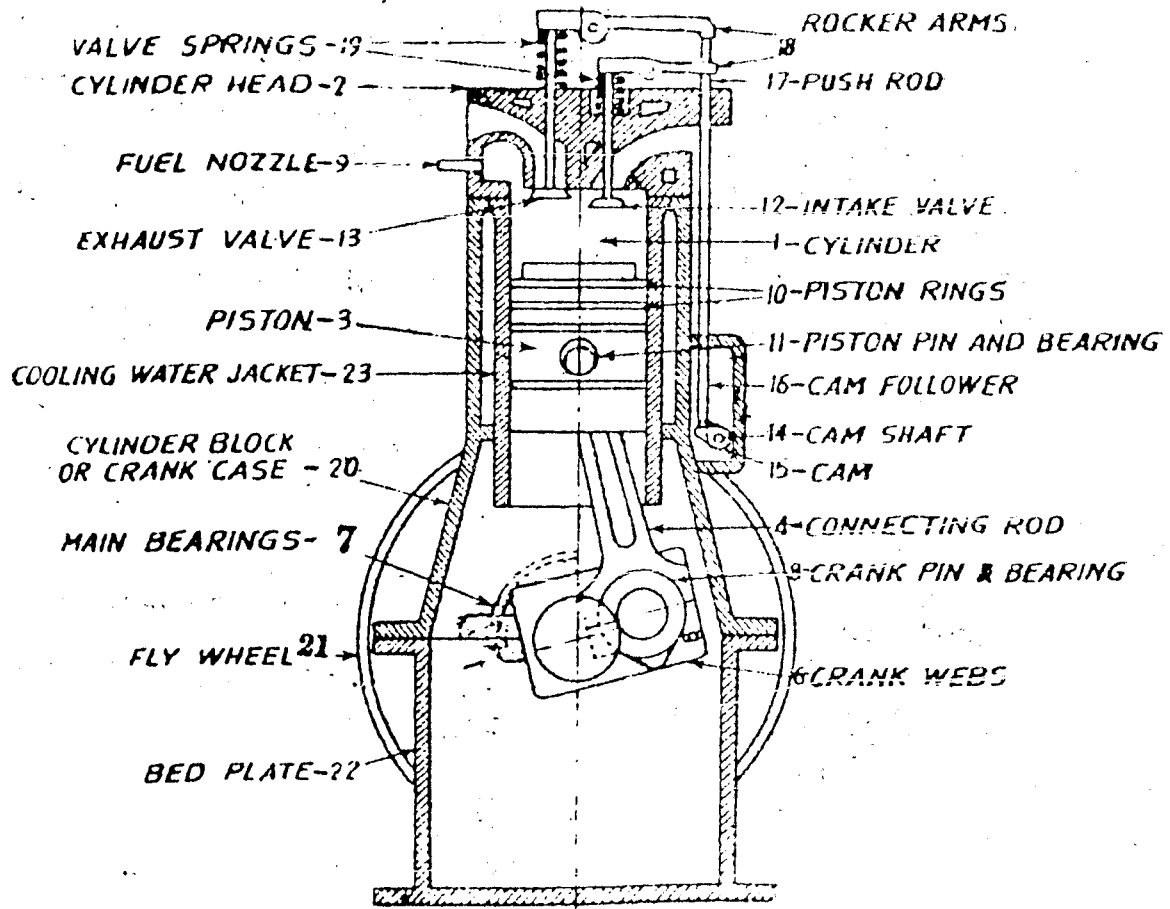

Major components of a diesel engine.

Fig 4-5

## **COMPONENTS OF DIESEL ENGINE :**

### **CYLINDER:**

The heart of the engine is the cylinder where the fuel is burnt and power developed. The inside of the cylinder is formed by the liner or sleeve. The inside diameter of the cylinder is called the bore.

### **CYLINDER HEAD:**

It closes one end of the cylinder and often contains the valves through which air and fuel are admitted and exhaust gases discharged.

### **PISTON:**

The other end of the working space of the cylinder is closed by the piston that transmits to the crank shaft the power developed by the burning of the fuel. The distance that the piston travels from one end of the cylinder to the other is called the stroke.

### **CONNECTING ROD:**

One end, called the small end of the connecting rod, is attached to the wrist pin located in the piston; the other end, or the big end has a bearing for the crank pin. The connecting rod changes and transmits the reciprocating motion of the piston to the continuously rotating crank pin during the

working stroke and vice versa during other strokes.

#### **CRANK SHAFT:**

The crank shaft runs under the action of piston through the connecting rod and crank pin located between crank webs or cheeks, and transmits the work from the piston to the driven shaft. The parts of the crank shafts supported by, and rotating in the main bearing are called the journals.

#### **FUEL NOZZLE:**

Fuel is delivered into the combustion space by an injection system consisting of a pump, fuel line and the fuel is delivered by this nozzle in a fine spray under pressure in Diesel engines.

#### **INTAKE VALVE:**

Fresh air enters through this valve operated by a cam.

#### **EXHAUST VALVE:**

The product of combustion after doing work on the piston are removed via this valve.

#### **FLYWHEEL:**

It takes care of the fluctuations of the cyclic variations in speed. It stores energy during

the power stroke and releases during the other stroke thus giving a fairly constant output torque.

#### **WORKING OF DIESEL ENGINE:-**

The diesel engine obtains its power from burning of fuel within the engine cylinder. The combustion of fuel produces increased temperatures and pressure in the cylinder and the pressure of developed gases pushes the piston out of the cylinder. Thus the mechanical power so developed is transmitted through the connecting rod to the crankshaft resulting into a turning effort. The working of the Diesel engine is shown in fig.4.6.

**1st stroke (suction stroke) :** During this stroke only air is charged in the cylinder. The suction valve should therefore remain open for 180 degree of the crankshaft rotation.

**2nd stroke (compression stroke) :** During this stroke air sucked in during the suction stroke is compressed. Both the suction valve and exhaust valve remain closed.

**3rd stroke (power stroke) :** During this stroke both the suction and exhaust valves remain closed. At this point higher pressure products of combustion are

The inlet valve is open and the descending piston draws in air to fill the cylinder with it.

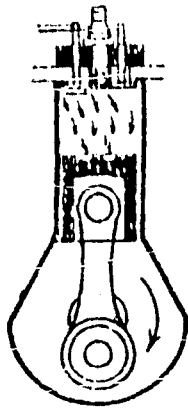

Air Intake Stroke  
(a)

All the valves are closed, rising piston compresses the air. The injection of fuel starts near end of compression.

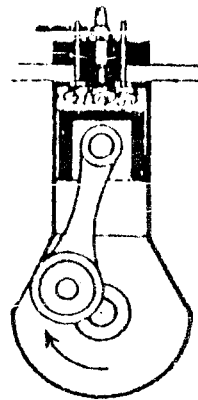

Compression Stroke  
(b)

All valves closed, the ignited mixture of air and fuel expands and forces the piston downward. This is a power stroke.

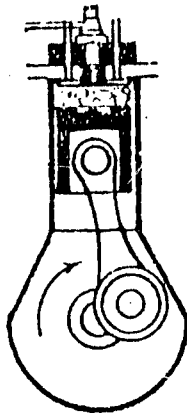

Expansion Stroke  
(c)

Only exhaust valve opens, the rising piston forces the burnt gases out of the cylinder.

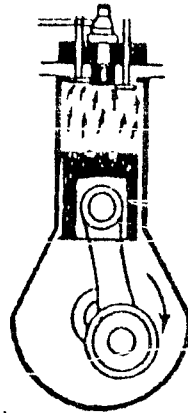

Exhaust Stroke  
(d)

Four Stroke Cycle of Diesel Engine

FIG 4.6



released, that is the ignited mixture of air and fuel expands and forces the piston downwards.

**4th stroke(exhaust storke)** : During this storke only exhaust valve opens. The rising piston forces the burnt gases out of the cylinder.

#### **4.9 THREE PHASE GENERATOR**

The generator is an electromechanical device whereby power supplied to rotate a mechanical shaft is converted to an electric voltage source capable of providing electric power. Mechanically, a generator consists of a **rotor** and a **stator**. The rotor is the rotating part of the machine driven by the shaft. A winding is placed on the rotor, which is excited by a dc current to establish a magnetic field that emanates radially from the rotor. The field is fixed in relation to the rotor but rotates in space as the rotor revolves. In high speed machines the rotor generates only one north and one south pole and is called a two-pole generator. Slower madhines can have many poles. If  $p$  is the number of poles, the + angular rate of the shaft, denoted by  $\omega_s$ , is related to the angular frequency  $\omega$  of the electric voltage according to

$$\omega_s = 2\omega/p$$

Generators in which shaft speed is locked or synchronized to the electric frequency are called **synchronous generators**.

## **OPERATION:**

The stator is the stationary part of the generator inside which the rotor revolves. Three windings, called **phase** or **load** windings, are placed on the stator; they are physically spaced in increments of 120 degrees around the periphery. As the magnetic field of the rotor revolves, it cuts the conductors of the three windings and induces a voltage in each by Faraday's law of electromagnetic induction.

## **METHODS OF EXCITATION:**

Two methods are used to provide the direct current required to excite the rotor's field winding. In smaller machines the winding is accessible through terminals having electric contacts, called brushes, that slide on **slip rings**. There is one slip ring for each end of the winding. Another method, used on larger machines, relies on rectification of the output of a small 3 phase ac generator mounted directly on the shaft of the synchronous generator. It is called a **brushless exciter**. The exciter requires a small dc field current to its stator. This current can either be externally provided or derived from rectifying the output of a small ac

generator. called a **pilot exciter**, that is also on the rotor's shaft. The pilot exciter is small enough that it can use permanent magnets on its rotor to provide its necessary magnetic field. The combination of brushless exciter and synchronous generator produces a machine with lower maintenance requirements, because no mechanical contacts are necessary between the rotor and the stator. When the pilot exciter is added, the generator becomes independent of any external electric power sources.

#### **4.10 D.C. SERIES MOTOR (SELF MOTOR)**

D.C. Series Motor of fractional H.P. is used for the starting purpose of the Diesel engine. This motor has a characteristic of decreasing speed for increasing loads. The motor is well suited for heavy starting torque. At starting the torque is proportional to square of the current, so this motors are utilised for starting of Diesel generator. A 12Volt D.C. supply is supplied from a battery to this motor.

#### **CHARACTERISTICS:**

1. Variable speed motor which adjust itself according to the load current.
2. This speed can also be varied by a

diverted resistances.

3. It has very heavy starting torque proportional to square of the load current.

It should be remember that series motor are never started at no load.

**MAIN COMPONENTS LIST:**

1. 12VOLT RELAY: 2 numbers
2. DUAL HEAD LAMP RELAY: 3 numbers (PMP 2103).
3. TRANSFORMER (230/12)VOLT: 1 number
4. CONTACTOR: 2 numbers (L&T)
5. SOLENOID: 1 number
6. TRANSISTOR(SL-100): 2 number
7. CAPACITOR: 100microFarad 1 number  
500microFarad 1 number  
0.047microFarad 2 number
8. 230 VOLT RELAY: 1 number
9. LEDS :4 numbers
- 10.DOUBLE POLE SINGLE THROW SWITCH:1 number
- 11.PUSH BUTTON(normally opened):2 numbers

## CHAPTER 5

### CONCLUSION

An automatic and semiautomatic remote controls for a diesel generator has been successfully developed. Both these methods have been tested. Any mode of operation at a time can be selected by just changing the position of mode selector switch.

Eventhough 10 seconds is enough to stop the generator, a timer circuit has been provided which can operate for 15 seconds for safety purpose. Another timer circuit can be installed to protect the stop solenoid, whenever the stop timer circuit fails to operate. This timer circuit protects the stop solenoid if the stop timer circuit becomes inactive. The added timer circuit can be designed to operate with more time lag than stop timer circuit (about 20 seconds).

The change over from normal to D.G. and vice versa takes place automatically.

The PCB required for this project is designed and fabricated. The cost of this

## REFERENCES

1. A.S.SHARO - "THERMAL ENGINEERING", SATHYA PRAKASHAN, NEW DELHI, 1982.
2. S.L.UPPAL - "ELECTRICAL POWER", KHANNA PUBLISHERS, NEW DELHI, 1965.
3. JACOB MILLMAN , CHRISTOS HALKIAS - "ELECTRONIC DEVICES AND CIRCUITS", MCGRAW HILL INTERNATIONAL EDITIONS, 1976.
4. K.A.SHAIKH - "SEMI AUTOMATIC REMOTE CONTROL FOR A DIESEL GENERATOR " , "ELECTRONICS FOR YOU", AUGUST 1985, P.67- 70
5. PEYTON Z.PEBLES, Jr., TAYEB A.GIUMA.- "PRINCIPLES OF ELECTRICAL ENGINEERING", MCGRAW-HILL, INC 1991.
6. RUSSELL MASON , "THE ART AND SCIENCE OF PROTECTIVE RELAYING " , WILEY EASTERN, 1971.